

**Mcc**  **Aviation** / AROLLA 3

Owner's manual 03/2021

# Summary

General Informations .....	4	Performance & use of brakes .....	15
Required piloting skills.....	5	Use of speed bar .....	16
General remarks about paragliding .....	5	Harness adjustment.....	17
Limits of use .....	6	Advice on maintenance.....	18
Operating the AROLLA 3 .....	7	Storage and transport.....	19
Preflight check of the paraglider .....	7	Check.....	20
Take-off.....	7	Before delivery .....	20
Landing .....	8	Periodic checks.....	20
Turning .....	8	Repair .....	20
Rapid descent techniques.....	9	Paragliding and nature conservation .....	21
Spiral dive.....	10	Recycling.....	22
B-line stall.....	11	Guarentee.....	22
Asymmetric or frontal (symmetric) collapses.....	12	Technical data and Information .....	23
Full stall .....	13	AROLLA 3.....	24
Overreaction-induced deep or full stall .....	13	Drawing of the risers .....	25
Steering without brakes.....	14	Sectional drawing of the AROLLA 3.....	25
Special steering.....	14	Plan of the lines .....	26
Comments on the testing procedures.....	14		

# Thank you for choosing Mcc Aviation!

Mcc Aviation Since more than 30 years, Mcc Aviation paragliders are well known for highest quality, lightness and durability.

Developed in Switzerland and produced in Europe, they are assembled from the best possible materials.

This owner's manual provides important information regarding the safe use of your paraglider and its maintenance. We do advise you to read it carefully before your first flight with your new AROLLA 3.

Should you have any question, please ask your dealer or contact us by email or by phone.

Further information about your glider or about other products from our range is available on our website:  
[www.mccaviation.ch](http://www.mccaviation.ch)

We wish you a lot of pleasure and many wonderful flights with your new wing !

**Team Mcc Aviation!**

# General Informations

Name of the models:

AROLLA 3 XSS, AROLLA 3 XS, AROLLA 3 S, AROLLA 3 M & AROLLA 3 L

Name & address of the manufacturer:

**Mcc Aviation SA**

Route de Forel 34

CH-1091 Grandvaux

Switzerland

[www.mccaviation.ch](http://www.mccaviation.ch)

[info@mccaviation.ch](mailto:info@mccaviation.ch)

The AROLLA 3 is certified in A category according to EN 926-2: 2013, EN 926-1: 2015 & NfL 91/09 standards.

Owner's manual version "March 2021".

This manual meets the requirements of EN 926-2: 2013 regarding the content and the information that have to be supplied to the end users.

The last update of this manual is available on [www.mccaviation.ch](http://www.mccaviation.ch)

## Required piloting skills

The AROLLA 3 is a paraglider with maximum passive safety and extremely forgiving flying characteristics. It proves to show good resistance to departures from normal flight.

## General remarks about paragliding

Paragliding is a risky sport ; a careful practise is therefore highly advisable.

The pilot must check the airworthiness of his equipment, and in particular of his paraglider before each single take-off. The pilot is the sole master aboard and flies at his own risks.

# Limits of use

The AROLLA 3 paragliders are certified for solo free flight only. Weather and thermal conditions must remain suitable for paragliding at any time and the very skills of the pilot have to be taken into account to decide whether to fly or not.

Moderate winds (4 on the Beaufort scale or 20-28 km/h ) can already be tricky due to turbulence near the ground on the leeward side behind obstacles or wind shears created by thermal activity.

Acrobatic maneuvers, which are maneuvers during which the canopy dives in pitch or roll over 30° from the trim straight glide shall not be considered as the normal use of your AROLLA 3 paraglider.

The pilot must comply at any time with laws and regulations applicable to paragliding.

The pilot should also comply with the requirements resulting from the certification (take-off load, dimensions of the harness, lines setting, brakes setting, etc.) and the safety information provided by this manual.

The behaviour of the AROLLA 3 when used on the winch or with an engine (paramotor) is not part of the certification according to the EN 926-2: 2013 standard.

# Operating the AROLLA 3

The AROLLA 3 requires no special or unusual operating technique. However you'll find hereunder some useful reminder which might help you to become more familiar with your new wing.

## **Preflight check of the paraglider**

**Contrôle Preflight check of the paraglider:** check the canopy for wears ; also check that the inner structure (ribs and diagonals) is not damaged and that the seams are all right.

**Check of the lines:** check that the lines, including the seams and the end loops are not damaged. Also check that the lines are not tangled and are perfectly sorted out.

**Check of the rapid links:** check that all the rapid links are screwed tight.

**Check of the risers:** Check that the risers are not damaged and are not twisted or tangled.

Check that the speed system can be operated freely and that the ropes are long enough as to avoid unintended operation of the speed system.

Check that the brake handles are in correct position and that the brake lines run freely through the brake pulleys.

## **Take-off**

Lay out the paraglider with the leading edge in a horseshoe shape. Holding the A risers close to the quick links move forward until the lines are tight.

You should now be perfectly centered in your wing. In nil wind or a light headwind, with lines tight take several strides. The AROLLA 3 will inflate rapidly and rise over your head.

Do not pull the risers too hard, either forward or down, as this could cause a collapse of the leading edge. Simply follow them with your arms until the glider reaches its angle of flight above your head.

It is important that the centre of gravity of your body remains in front of your feet during inflation of the glider so that the load through the risers remains constant.

A controlled inflation avoids excessive need of the brakes and allows you to visually check the wing and lines during the last phase of the launch, before acceleration to takeoff speed.

Depending on the wind conditions or the slope, judicious use of the brakes may assist a cleaner launch.

## **Landing**

Due to the fine glide and lift of AROLLA 3, caution is recommended during approach and landing.

AROLLA 3 is an agile and sensitive glider. Each brake input may initiate a significant glider reaction. It is therefore recommended that first flights are performed in a familiar environment, on a large landing site and under stable meteorological conditions.

An advantage of negative steering is that there is more time for maneuvers to be performed precisely, resulting in reduced pendular motion of the paraglider.

Reminder: negative steering involves slowing the glider by applying brakes symmetrically to about 30% of the maximum range, then effecting a turn by steadily releasing the outside brake.

Speeding up just prior to landing allows a more effective flare and a gentler touch-down in nil or light winds

## **Turning**

AROLLA 3 is designed to turn efficiently and will core thermals even without the need for weight-shift piloting.

Negative steering (see above) slows the paraglider in certain phases of flight and consequently reduces excessive roll during turn reversals.

Your glider is not only designed to turn rapidly (with approx. 30% brake) but also to fly slowly in order to help identify areas of lift and to maintain a flatter turn to minimize sink rate during the turn (with 15% brake).

Symmetrical brake-input of approximately 20% enables you to control the glider, to brake further if the canopy pitches forward and to release if the canopy pitches backwards.



# Rapid descent techniques

As a general rule, in order to descend, fly away from areas of lift. If, for whatever reason, you are taken unawares by the development of conditions, you may consider using the following techniques to increase your sink rate.

## **Big ears**

Grab the first risers in the front (risers with a red cover and one single line) and then pull them down by making an arc of circle outwards and downwards until the wingtip folds back under the leading edge. We recommended that you perform each “ear” successively and not both simultaneously.

Keep the risers taut to prevent the wingtips from reopening until the maneuver is finished. Depending on the size of the big ears initiated, the sink rate can increase by up to 3–4 m/s. If necessary, it is possible to initiate small alterations in direction by weight shift control.

As soon as the risers are released, the paraglider should spontaneously reopen. However, you can speed up the reopening by „pumping“ the brakes in a single sweeping movement. When pumping the brakes it is recommended that one side of the paraglider be opened after the other. Pulling both brakes simultaneously to reopen ears may result in a stall.

## Spiral dive

AROLLA 3 is a manoeuvrable wing that responds to pilot input precisely and progressively.

To initiate a tight spiral, apply one brake progressively to about 35% and hold it in this position. The speed of rotation and the brake pressure will increase progressively and the centrifugal force on the pilot will also increase.

The angle and speed of rotation can be decreased or increased by releasing or depressing the brake by several centimeters respectively.

Once mastered, the spiral dive allows you to descend at rates greater than 10 m/s.

Extremely abrupt or badly synchronised brake inputs or too rapid initiation of the spiral may result in an asymmetrical collapse and/or a spin.

## CAUTION!

A deep spiral is a radical manoeuvre. The kinetic energy generated must be dissipated by slowly releasing the inside brake throughout, at least, one whole revolution.

# B-line stall

Grasp the B-risers at the quick links, and ease them down symmetrically. Do not snatch them down.

The paraglider will enter a B-line stall and feel to drop backwards before the pilot stabilises underneath the wing. The descent rate increases to 6 - 8 m/s.

To exit the B-line stall raise both hands together in a single, positive movement so that the risers are at normal full extension again.

On releasing the B-risers, your AROLLA 3 should return immediately to normal flight.

An adjustment error, control error or certain aerological conditions may lead to a prolonged deep stall phase. A push on the speed bar should initiate rapid exit from the B-line stall state.

If the speed bar is not connected, pulling on the A-risers by 3-5 cm will have the same result.

## **CAUTION!**

Unlike big ears and spiral dives (see above) a glider in a B-line stall is in a true stalled position.

For this reason, a B-line stall should never be performed close to the ground.

# Asymmetric or frontal (symmetric) collapses

Despite tests showing that AROLLA 3 recovers spontaneously after collapses, active piloting is recommended in the event of an asymmetric or frontal collapse. Active piloting will reduce the loss of altitude and a change of direction.

**In the event of a frontal (symmetric) collapse:** before automatic reopening occurs, bring both brakes down swiftly & symmetrically to speed up reopening of the leading edge, then immediately bring your hands back up to normal flying position.

**In the event of an asymmetric collapse:** keep the paraglider flying as straight as possible by leaning away from the collapsed side and applying sufficient (just enough, not too much) brake to maintain course. Speed up the reopening of the closed side by a single, positive input.

# Full stall

Certain pilot behaviour or weather conditions can cause a full stall. This is a serious deviation from normal flight and can be difficult to manage. If a stall occurs at less than 100 m above the ground, throw your reserve parachute immediately.

## **Overreaction-induced deep or full stall**

One Poorly timed or excessive use of the brakes when the air speed of the wing is reduced (e. g. when coming out of a spiral or speeding up after a B-line stall).

Rain-induced deep or full stall.

A soaked or heavily drenched leading edge (from rain or a cloud) can result in a full stall or deep stall due to uneven airflow over the leading edge as a result of rain drops and an increase of weight to the wing.

Whatever the cause, a stall can be either symmetrical or asymmetric (a spin). In both cases the brake line travel becomes very short and even small input may suddenly induce an airflow separation; in some cases even a gust or a

sudden thermal may change the angle of incidence enough to cause the deep stall.

If you find yourself flying in unavoidable rain we strongly recommend that you avoid any sudden movements or radical brake line input, that you do not pull big ears or B-stall, and that you steer clear of turbulence and avoid a deep flare on landing.

A moderate use of the speed system to increase the speed of your glider can reduce the risk of rain-induced stall.

Whatever the cause of the full stall, the pilot has two possible courses of action:

If the full stall happens above 100 m, it is strongly recommended to initiate standard stall recovery assuming the pilot is familiar with the process (i.e. a complete execution of the full stall, stabilization of the wing and progressive lifting of the hands to resume normal flight).

If the full stall happens below 100 m or if the pilot is unfamiliar with stall recovery, the reserve parachute should be deployed immediately.

# Steering without brakes

If a brake line or pulley breaks it is possible to steer AROLLA 3 using the D-risers (rear risers).

The movements should be finely controlled as the deformation of the wing due to the traction on the D-risers is greater than that produced by using the brakes.

**Tip:**

Practice this method of steering to be prepared before a real brake failure !

**Special steering**

No other maneuver or steering technique is recommended.

**Comments on the testing procedures**

All maneuvers have been carried out over water in a stable air mass with standard temperature, humidity and pressure.

They have been carried out by professional pilots trained to react to any problem in the most appropriate manner.

Test reports are available on our website:  
[www.mccaviation.ch](http://www.mccaviation.ch) and on the test laboratory website:  
[www.para-test.com](http://www.para-test.com)

# Performance & use of brakes

AROLLA 3's best glide is at trim speed (no brakes) – about 36-37 km/h.

The minimum sink rate is achieved by applying approx. 15% brake.

When using more than 30% brake the aerodynamics and the performance of the glider deteriorate and the brake pressure increases rapidly.

The higher the brake pressure, the greater the risk of an impending stall which will occur at full brake travel (100% brake).

In normal flying conditions the optimum brake position, in terms of performance and safety, is within the top third of the braking range.

# Use of speed bar

Your AROLLA 3 is equipped with a highly efficient speed system. For fitting and positioning of the accelerator system and speed bar, consult the instructions provided by your harness manufacturer.

Before each take-off, check that the entire accelerator system works freely and that the lines are long enough

to prevent the speed bar from being activated involuntarily in flight (speed lines too short).

If the harness is fitted with a front mounted reserve, the speed bar lines must pass under the reserve container and the reserve bridle so that the reserve can be deployed correctly.

Use of the speed bar increases the maximum speed of the paraglider by up to 25% of the trim speed. Whilst the AROLLA 3 remains stable at full speed, no paraglider is immune from deflations in certain conditions and the deflation point can be sudden when flying at high speed.

Use of the speed system does reduce the angle of attack and there is therefore an increased risk of a frontal or asymmetric collapse. For this reason we do not advise the use of the speed system near to the ground or in turbulent air.



# Harness adjustment

During testing procedures, the pilots have been using ABS type harnesses with following dimensions:

	Distance from seatboard to inner bottom of carabiners	Distance between centerlines of inner bottom of carabiners
AROLLA 3 XXS	39-42 cm	38-42 cm
AROLLA 3 XS	39-43 cm	39-44 cm
AROLLA 3 S	40-44 cm	41-46 cm
AROLLA 3 M	41-45 cm	43-48 cm
AROLLA 3 L	42-46 cm	44-50 cm

We recommend the use of a harness with adjustments as close as possible to those used during the certification tests.

Excessive cross-bracing (chest strap very tight) increases the risk of risers twisting during certain manoeuvres.

A looser setting may result in a tendency to fall towards the collapsed side.

Lower hang-points reduce the roll-stability of your harness and can slow down reopening of asymmetric collapses.

# Advice on maintenance

Avoid dropping the canopy on its top surface or on its leading edge during inflation or landing.

- Do not drag it across the ground when moving it.
- Do not expose it unnecessarily to sunlight.
- Choose a folding technique that does not damage the leading edge and that does not crease the internal structure excessively.
- To maximize the life of your glider we do not recommend the use of stuff sacks; the creasing of the material will decrease the life expectancy of the fabric, in particular for the internal structure.
- Always use the protective bag to avoid direct contact with the harnesses and buckles, and unwanted frictions inside the rucksack.
- Never store your paraglider when it is damp. If immersed in sea water, rinse it thoroughly in fresh water. Do not use any detergents.
- If you do most of your flying near the sea, where the air is humid and salty, the wing may age faster. In this case we suggest you have it checked more often than prescribed in this manual.
- Empty any foreign bodies from your paraglider regularly, for example sand, stones or animal or vegetable matter which may eventually decay. Twigs, sand, pebbles, etc... damage the fabric in successive folds, and organic debris of vegetable or animal origin (insects) can promote mold growth.

AROLLA 3 is fitted with debris release slots at the wing tips. Debris can be shaken from the closed cells through to the wing tip and the release slot opened to remove particles. Check that you reseal the debris release slot when completed.

# Storage and transport

Store your loosely packed glider in a cool (10-25°C) and dry (< 60% humidity) place. Hot car boots or damp basements lead to damaging of the cloth.

A paraglider should always be dry when packed, but this is particularly important after the last flight of the season. But even a completely dry wing should still be stored open in a dry, clean and dark place.

If you do not have room for such winter storage we recommend you open all compression straps on the bag as much as possible and leave the bag open so that air can circulate around the packed canopy.

Make sure no vermin make their sleeping quarters in your wing, and keep it well distant from solvents and acids. Petrol and other petrochemicals are especially abrasive for nylon and will damage the cloth if allowed near.

High temperatures in combination with moisture are a particularly volatile mix that will accelerate the hydrolysis process where the fibres and the coating are decomposed.

# Check

## **Before delivery**

Your paraglider has been carefully checked throughout the whole production process in our production facility. It has been double-checked and measured in our workshop in Grandvaux in Switzerland and it has been tested in flight by a professional pilot.

It is delivered with the standard lines and brakes settings which matches the settings used during the certification flights.

## **Periodic checks**

For your own safety, your paraglider must be checked every two years or after 100 flight hours whichever is sooner and anytime there is a noticeable change in its behaviour.

The checks must be done by Mcc Aviation in Grandvaux or by an authorised representative.

For those pilots who understand that a perfectly trimmed paraglider performs better, we do advise a yearly checking and tuning of the geometry of the lines.

# Repair

Repairs should be achieved by a specialist. The use of ill fitted spare parts or materials or a wrong repair process can be very dangerous on an aircraft. For safety reasons, always have your paraglider repaired by a specialist.

Our workshop is equipped as a production facility, with all machines, original materials and spare parts and run by trained staff.

# Paragliding and nature conservation

Being a good pilot is not only knowing how to take-off, land and fly long distances, it is also being conscious about the beautiful natural surrounding and behaving in a way that helps to protect the environment.

Take only pictures and memories and leave at most footprints. Keep on the footpath, do not damage the vegetation and do not disturb the wildlife.

# Recycling

Your paraglider is mainly (99%) made with plastic materials (polyamide, polyester, etc.) and with some metal parts (quick links, pulleys, rings), which can easily be put aside.

# Guarentee

Mcc Aviation new paragliders are covered by a guarantee according to the law (cf. art. 197 CO or art.5 of the directive 1999/44/CE).

Mcc Aviation SA commits itself to correct a possible defect or replace the faulty piece. The guarantee period starts from the date of delivery of the paraglider to the authorized dealer.

The guarantee does not cover damage caused by normal aging, by an accident, by misuse or by neglecting the regular maintenance.

# Technical data and Information

Number of risers: 4 risers (A, B, C & D)

No trimmers on the certified models.

Minimum brake range to stall point according to EN 926-2: 2013 standard:

AROLLA 3 XXS & XS: 60 cm

AROLLA 3 S, M & L: 65 cm

The setting of the lines and of the brakes must at all time remain within the allowances, as required by the EN 926-2: 2013 standard (+/- 1 cm compared to the total length as indicated on the list of lines and plan of lines).

Maximum travel of accelerator according to EN 926-2: 2013 standard:

AROLLA 3 XXS : 15.0 cm

AROLLA 3 XS : 14.0 cm

AROLLA 3 S : 15.0 cm

AROLLA 3 M : 16.0 cm

AROLLA 3 L : 16.5 cm

Except for brakes and speed system, there is no other adjustable devices available on the certified models.

Lists of lines on request.

<b>AROLLA 3</b>		<b>XXS</b>	<b>XS</b>	<b>S</b>	<b>M</b>	<b>L</b>
<b>Total weight in flight <sup>1)</sup> Paragliding use EN-A*</b>	kg	52-65	52-70	63-87	79-103	94-120
<b>Total weight in flight <sup>1)</sup> Mini-wing use EN-B**</b>	kg	65-90	70-100	87-110	103-120	120-140
<b>Flat area</b>	m <sup>2</sup>	20.56	22.23	24.05	26.01	28.13
<b>Flat area</b>	m <sup>2</sup>	18.25	19.73	21.35	23.09	24.97
<b>Scale flat</b>	m	9.83	10.22	10.63	11.06	11.25
<b>Projected span</b>	m	7.8	8.11	8.43	8.77	9.12
<b>Flat aspect ratio</b>		4.73	4.73	4.73	4.73	4.73
<b>Projected aspect ratio</b>		3.35	3.35	3.35	3.35	3.35
<b>Number of cells</b>		38	38	38	38	38
<b>Paraglider weight</b>	kg	2.70	2.85	3.00	3.15	3.30
<b>Speed min.-trim.-max. EN-A*</b>	km/h	23-37-45	23-37-45	23-37-45	23-37-45	23-37-45
<b>Speed min.-trim.-max. EN-B**</b>	km/h	27-43-54	27-43-54	26-42-52	24-41-51	24-40-50
<b>Certification</b>	EN/LTF	A* / B**	A* / B**	A* / B**	A* / B**	A

1) Pilot with all equipment, ready for take off



# Drawing of the risers

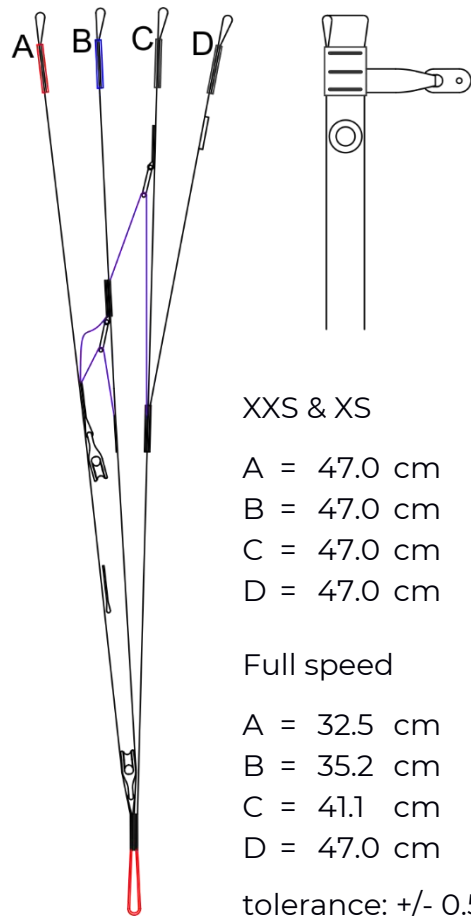

XXS & XS

- A = 47.0 cm
- B = 47.0 cm
- C = 47.0 cm
- D = 47.0 cm

Full speed

- A = 32.5 cm
- B = 35.2 cm
- C = 41.1 cm
- D = 47.0 cm

tolerance: +/- 0.5 cm

S, M & L

- A = 50.0 cm
- B = 50.0 cm
- C = 50.0 cm
- D = 50.0 cm

Full speed

- A = 34.0 cm
- B = 37.0 cm
- C = 43.5 cm
- D = 50.0 cm

tolerance: +/- 0.5 cm

# Sectional drawing of the AROLLA 3

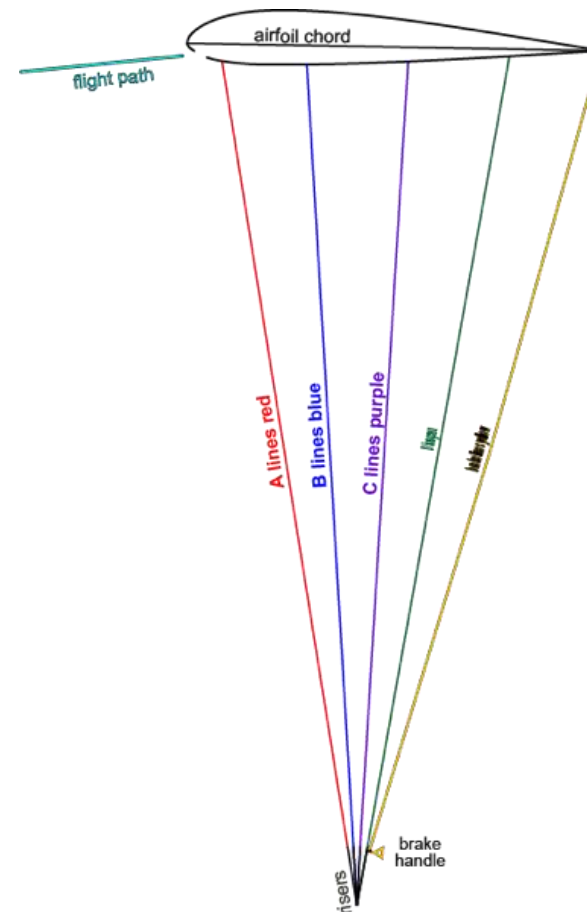

# Plan of the lines

**AROLLA 3 XXS / XS / S / M / L**

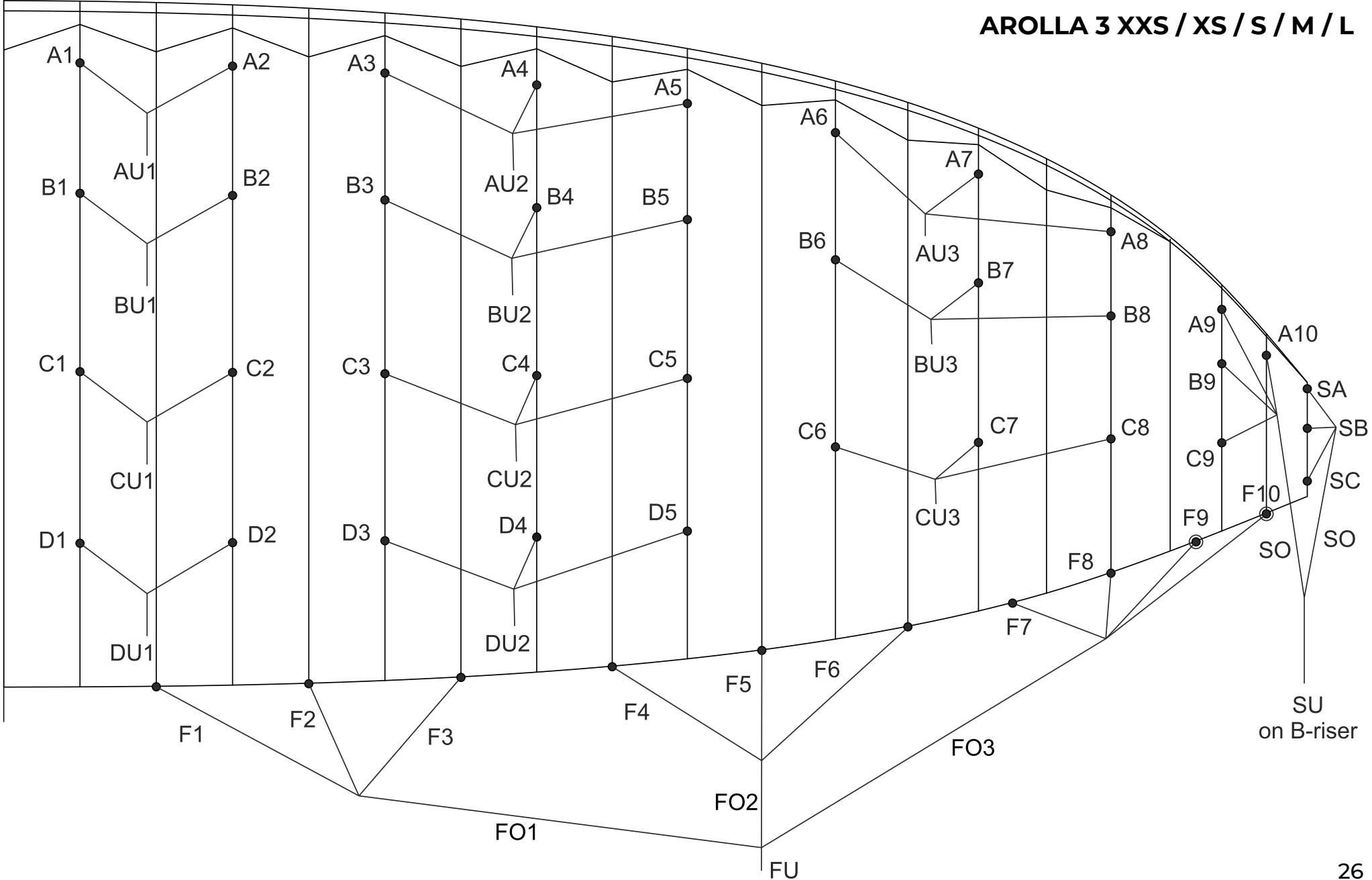



**Mcc Aviation SA**

Route de Forel 34  
CH-1091 Grandvaux

**Contact information**

Phone: +41 21 781 26 26  
Email: [info@mccaviation.ch](mailto:info@mccaviation.ch)

**Opening time**

Monday - Friday  
8h00-12h00 / 13h00-17h00